



# Hilti HIT-HY 100



[qr.hilti.com/  
manual/?id=2080669](http://qr.hilti.com/manual/?id=2080669)

English  
Français  
Español  
Português  
Русский



(A, B)



(A)



(B)

## DANGER

**Contains:** hydroxypropyl methacrylate(A),  
boric acid (A), dibenzoyl peroxide(B)

May cause an allergic skin reaction. (A,B)

Causes serious eye irritation (A).

May damage fertility or the unborn child. (A)

Very toxic to aquatic life. (B)





















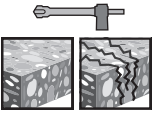

ICC ESR 3574

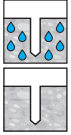

IAPMO-UES  
ER 547

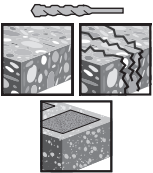

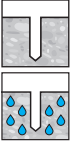
<p><b>en</b></p>	<p><b>Adhesive anchoring system for rebar and anchor fastenings in concrete.</b>                  Read the safety precautions, safety data sheet, and the product information before use.                  Read the safety precautions and the product information of the accessories before use.</p>	<p>→  20..21</p>
<p><b>fr</b></p>	<p><b>Mortier de scellement pour ancrage d'armatures métalliques et de tiges filetées dans le béton.</b>                  Avant utilisation, bien lire les prescriptions de sécurité, la fiche de données de sécurité ainsi que la fiche d'information produit. Avant d'utiliser l'accessoire, bien lire les prescriptions de sécurité ainsi que la fiche d'information produit.</p>	<p>→  22..23</p>
<p><b>es</b></p>	<p><b>Resina de inyección para barras corrugadas y varilla roscada.</b>                  Lea las indicaciones de seguridad, la hoja de datos de seguridad y la información del producto antes de utilizarlo. Lea las indicaciones de seguridad y la información del producto antes de utilizar los accesorios.</p>	<p>→  24..25</p>
<p><b>pt</b></p>	<p><b>Buchas químicas para ferros de armadura e barras roscadas em betão.</b>                  Antes de utilizar, ler as regras de segurança, a ficha técnica de segurança e os dados informativos sobre o produto. Antes de utilizar os acessórios, ler as regras de segurança e os dados informativos sobre o produto.</p>	<p>→  26..27</p>
<p><b>ru</b></p>	<p><b>Связующий состав для крепления арматурных и резьбовых стержней в бетоне.</b>                  Перед использованием ознакомьтесь с предписаниями по технике безопасности, сертификатом безопасности и информацией о продукте.                  Перед использованием дополнительного приспособления ознакомьтесь с предписаниями по технике безопасности и информацией о продукте.</p>	<p> 28..29</p>

						
<b>1</b>		HIT-V HAS  Rebar  HIS-N 		$5/8'' \dots 1 1/8''$ 16 ... 32 mm	$2 3/8'' \dots 25 3/8''$ 60 ... 640 mm	
<b>2</b>		HIT-V HAS  Rebar 		$7/16'' \dots 1 1/2''$ 10 ... 40 mm	$2 3/8'' \dots 25''$ 60 ... 640 mm	



**en** Dry concrete

Water saturated  
concrete

Hammer drilling

Hollow drill bit

**fr** Béton sec

Béton saturé d'eau

Perçage avec  
percussion

Foret creux

**es** Hormigón seco

Hormigón saturado  
de agua

Taladro con percusión

Taladro con broca hueca  
y aspiración

**pt** Betão seco

Betão saturado de água

Perfurar de martelo

Broca de coroa oca

**ru** Сухой бетон

Водонасыщенный  
бетон

Ударное сверление

Пустотелый бур

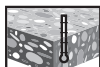

**en** Uncracked concrete

Cracked concrete

Grout-filled CMU

Temperature of  
base material

**fr** Béton non lézardé

Béton lézardé

CMU rempli de mortier

Température du  
matériau support

**es** Hormigón no fisurado

Hormigón fisurado

CMU relleno con mortero

Temperatura de la  
superficie de trabajo

**pt** Betão não fissurado

Betão fissurado

CMU preenchido  
com argamassa

Temperatura do  
material base

**ru** Нерастрескавшийся  
бетон

Растрескавшийся  
бетон

Температура базового  
материала

Бетонные блоки





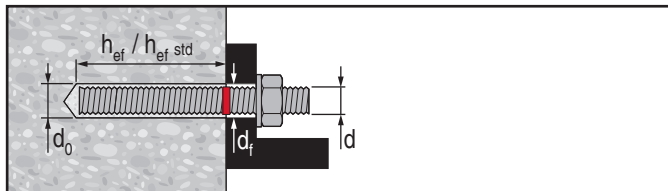

<b>en</b>	Threaded rod Threaded sleeve	Rebar	cartridge temperature	Working time	Curing time
<b>fr</b>	Tige filetée Douille filetée	Armature métallique	Température de la cartouche	Temps de manipulation	Temps de durcissement
<b>es</b>	Varilla roscada Manguito roscado	Barras corrugadas para armado	Temperatura del cartucho	Tiempo de ajuste	Tiempo de fraguado
<b>pt</b>	Barra roscada Casquilho roscado	Ferros de armadura	Temperatura do cartucho	Tempo de trabalho	Tempo de cura total
<b>ru</b>	Резьбовой стержень Резьбовая втулка	Арматурная сталь	Температура картриджа	Время схватывания	Время отвердевания

HAS, HIT-V





 Ø d [inch]	Ø d <sub>0</sub> [inch]	h <sub>ef</sub> [inch]	T <sub>inst</sub> [ft-lb]	T <sub>inst</sub> [Nm]
3/8	7/16	2 3/8 ... 7 1/2	15	20
1/2	9/16	2 3/4 ... 10	30	41
5/8	3/4	3 1/8 ... 12 1/2	60	81
3/4	7/8	3 1/2 ... 15	100	136
7/8	1	3 1/2 ... 17 1/2	125	169
1	1 1/8	4 ... 20	150	203
1 1/4	1 3/8	5 ... 25	200	271

d <sub>i</sub> [inch]	HAS, HIT-V	3/8	1/2	5/8	3/4	7/8	1	1 1/4
d <sub>f1</sub>		1/2	5/8	13/16*	15/16*	1 1/8*	1 1/4*	1 1/2*
d <sub>f2</sub>		7/16	9/16	11/16	13/16	15/16	1 1/8	1 3/8

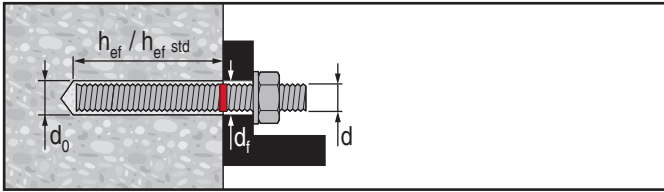

HIT-V



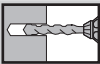

 Ø d [mm]	Ø d <sub>0</sub> [mm]	h <sub>ef</sub> [mm]	T <sub>inst</sub> [Nm]
M8	10	60...160	10
M10	12	60...200	20
M12	14	70...240	40
M16	18	80...320	80
M20	22	90...400	150
M24	28	96...480	200
M27	30	108...540	270
M30	35	120...600	300

d <sub>f</sub> [mm]	HIT-V	M8	M10	M12	M16	M20	M24	M27	M30
d <sub>f1</sub>		11	14	16	20*	24*	30*	32*	37*
d <sub>f2</sub>		9	12	14	18	22	26	30	33

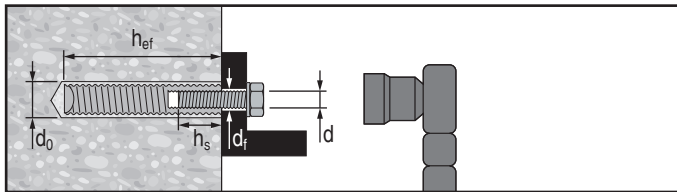

**HIS-N**



 Ø d [inch]	Ø d <sub>0</sub> [inch]	h <sub>ef</sub> [inch]	Ø d <sub>f</sub> [inch]	h <sub>s</sub> [inch]	T <sub>inst</sub> [ft-lb]	T <sub>inst</sub> [Nm]
3/8	1 1/16	4 3/8	7/16	3/8...1 5/16	15	20
1/2	7/8	5	9/16	1/2...1 3/16	30	41
5/8	1 1/8	6 3/4	1 1/16	5/8...1 1/2	60	81
3/4	1 1/4	8 1/8	1 3/16	3/4...1 7/8	100	136

 Ø d [mm]	Ø d <sub>0</sub> [mm]	h <sub>ef</sub> [mm]	Ø d <sub>f</sub> [mm]	h <sub>s</sub> [mm]	T <sub>inst</sub> [Nm]
M8	14	90	9	8...20	10
M10	18	110	12	10...25	20
M12	22	125	14	12...30	40
M16	28	170	18	16...40	80
M20	32	205	22	20...50	150

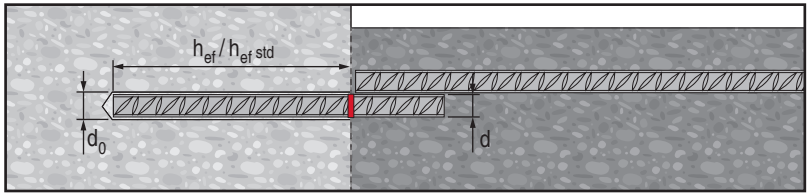
## Rebar





## US Rebar





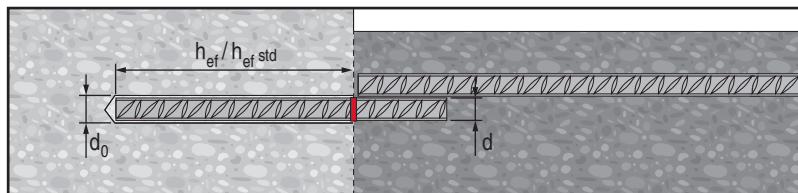





 d	$\varnothing d_0$ [inch]	$h_{ef}$ [inch]
#3	$\frac{1}{2}$	$2\frac{3}{8} \dots 7\frac{1}{2}$
#4	$\frac{5}{8}$	$2\frac{3}{4} \dots 10$
#5	$\frac{3}{4}$	$3\frac{1}{8} \dots 12\frac{1}{2}$
#6	$\frac{7}{8}$	$3\frac{1}{2} \dots 15$
#7	1	$3\frac{1}{2} \dots 17\frac{1}{2}$
#8	$1\frac{1}{8}$	4...20
#9	$1\frac{3}{8}$	$4\frac{1}{2} \dots 22\frac{1}{2}$
#10	$1\frac{1}{2}$	5...25

## CA Rebar

 d	$\varnothing d_0$ [inch]	$h_{ef}$ [mm]
10 M	$\frac{9}{16}$	70...226
15 M	$\frac{3}{4}$	80...320
20 M	1	90...390
25 M	$1\frac{1}{4}$	101...504
30 M	$1\frac{1}{2}$	120...598





**Rebar**

**EU Rebar**



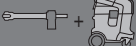

 $\varnothing d$ [mm]	$\varnothing d_0$ [mm]	$h_{ef}$ [mm]
8	12	60...160
10	14	60...200
12	16	70...240
14	18	75...280
16	20	80...320
18	22	85...360
20	25	90...400
22	28	95...440
24	32	96...480
25	32	100...500
26	35	104...520
28	35	112...560
30	37	120...600
32	40	128...640

		HAS HIT-V 	HIS-N 	Rebar 	 HIT-RB 	 HIT-SZ 	HIT-DL 	HIT-OHC 
$d_0$ [inch]		$d$ [inch]			[inch]	[inch]	[inch]	Art. No.
7/16	–	3/8	–	–	7/16	–	–	387551
1/2	–	–	–	#3	1/2	1/2	1/2	
9/16	–	1/2	–	10M	9/16	9/16	9/16	
5/8	5/8	–	–	#4	5/8	5/8	9/16	
11/16	11/16	–	3/8	–	11/16	11/16	11/16	
3/4	3/4	5/8	–	15M #5	3/4	3/4	3/4	
7/8	7/8	3/4	1/2	#6	7/8	7/8	7/8	387552
1	1	7/8	–	20M #7	1	1	1	
1 1/8	1 1/8	1	5/8	#8	1 1/8	1 1/8	1	
1 1/4	–	–	3/4	25M	1 1/4	1 1/4	1	
1 3/8	–	1 1/4	–	#9	1 3/8	1 3/8	1 3/8	
1 1/2	–	–	–	30M #10	1 1/2	1 1/2	1 3/8	

 HIT-DL:  $h_{ef} > 10''$ 











 HIT-RB:  $h_{ef} > 20d$ 

Hilti VC 150/300 	HIT-RE-M 		HIT-OHW 
	Art. No.		Art. No.
min. 61 l/s	337111	HDM 330, HDM 500 HDE 500-A22	387550

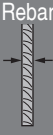
			
$d_0$ [inch]	[inch]	Art. No. 381215	
7/16" ... 1 1/8"	2 3/8" ... 20"	✓	–
1 1/4" ... 1 1/2"	4" ... 25"	–	✓
			≥ 6 bar/90 psi
			≥ 140 m³/h / ≥ 82 CFM

\* Manual hand pump option only valid under ETA approvals (ETA 14/0001 and ETA 14/0009)





# Hilti HIT-HY 100





		HAS HIT-V 	HIS-N 	Rebar 	 HIT-RB 	 HIT-SZ 	HIT-DL 	HIT-OHC 
$d_0$ [mm]		d [mm]			[mm]	[mm]	Art. No.	
10	–	8	–	–	10	–	–	387551
12	–	10	–	8	12	12	12	
14	–	12	8	10	14	14	14	
16	16	–	–	12	16	16	16	
18	18	16	10	14	18	18	18	
20	20	–	–	16	20	20	20	
22	22	20	12	18	22	22	20	
25	25	–	–	20	25	25	25	
28	28	24	16	22	28	28	25	387552
30	30	27	–	–	30	30	25	
32	32	–	20	24/25	32	32	32	
35	–	30	–	26/28	35	35	32	
37	–	–	–	30	37	37	32	
40	–	–	–	32	40	40	32	

HIT-DL:  $h_{ef} > 250$  mm

HIT-RB:  $h_{ef} > 20d$



Hilti VC 20/40 (-Y) 	HIT-RE-M  Art. No.		HIT-OHW  Art. No.
min. 61 l/s	337111	HDM 330 / 500 HDE 500-A22	387550

	 $h_{ef}$		
$d_0$ [mm]	[mm]	Art. No. 381215	
10...32	60...500	✓	–
35...40	100...640	–	✓
≥ 6 bar/90 psi ≥ 140 m³/h			



 HIT-HY 100



HIT-V, HAS 

HIS-N 

Rebar 

[°C]

[°F]

  $t_{work}$

  $t_{cure}$

-10...-5

14...22

3 h

12 h

-4...0

23...31

40 min

4 h

1...5

32...40

20 min

2 h

6...10

41...50

8 min

60 min

11...20

51...68

8 min

60 min

21...30

69...86

5 min

30 min

31...40

87...104

2 min

30 min

1

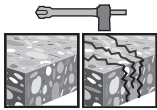



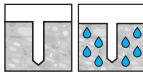



HAS/HIT-V  
HIS-N  
Rebar

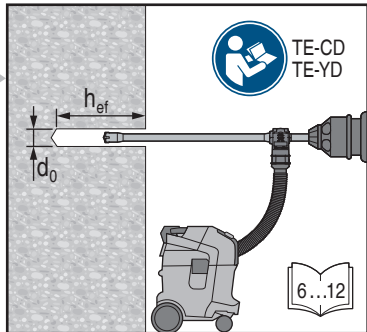

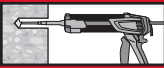
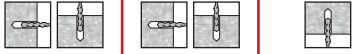
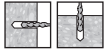
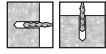
$d_0$ :  
5/8" ... 1 1/8"  
16 ... 32 mm

$h_{ef}$ :  
2 3/8" ... 25 3/8"  
60 ... 640 mm



	A	B	C
			
	2 3/8" ... 9 7/8" 60 ... 250 mm	2 3/8" ... 25" 60 ... 640 mm	2 3/8" ... 25" 60 ... 640 mm
			

2

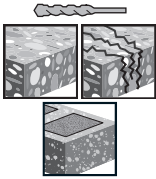

HIT-V  
HAS



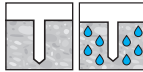



Rebar

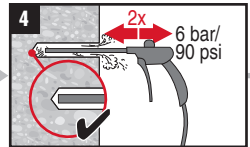
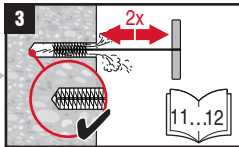
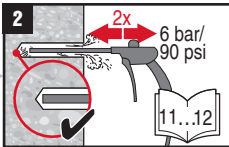
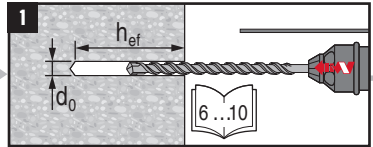

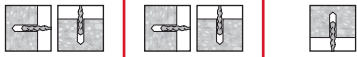
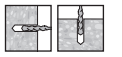
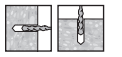
$d_0$ :  
7/16" ... 1 1/2"  
10 ... 40 mm

$h_{ef}$ :  
2 3/8" ... 25"  
60 ... 640 mm

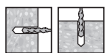

	A	B	C
			
	2 3/8" ... 9 7/8" 60 ... 250 mm	2 3/8" ... 25" 60 ... 640 mm	2 3/8" ... 25" 60 ... 640 mm
			

**A**

$h_{ef}$ :  
 $2\frac{3}{8}'' \dots 9\frac{7}{8}''$   
 60...250 mm

HAS/HIT-V   
 HIS-N   
 Rebar 



HIT-RE-M →

11...12

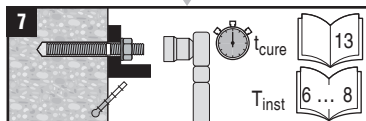
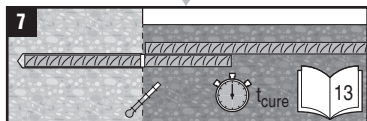
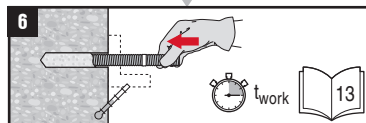
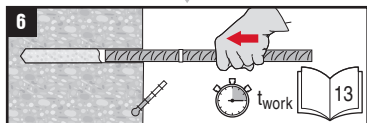
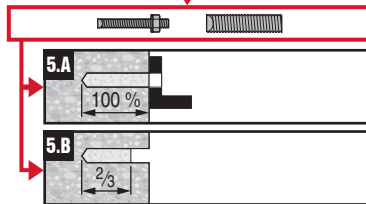
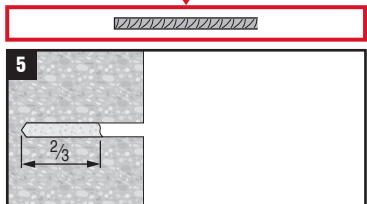
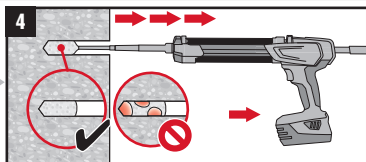
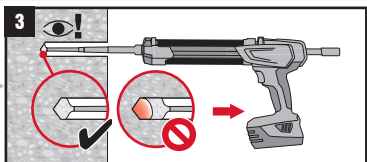
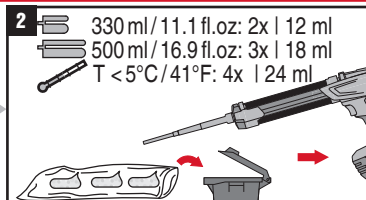
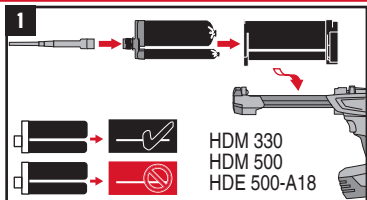

**B**

$h_{ef}$ :  
2 3/8" ... 25"  
60...640 mm

HAS/HIT-V

Rebar

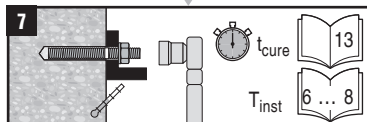
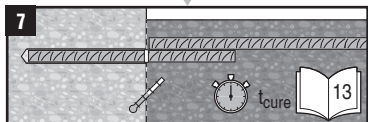
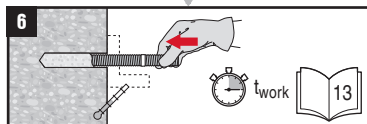
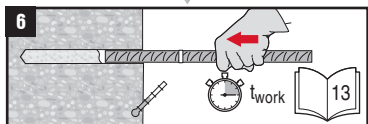
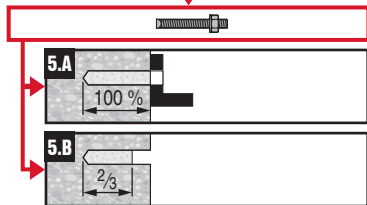
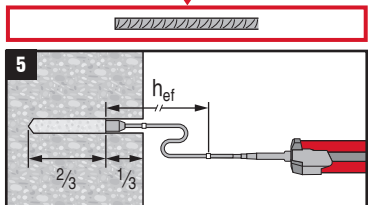
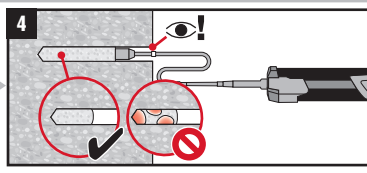
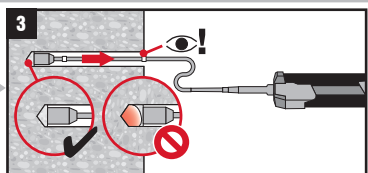
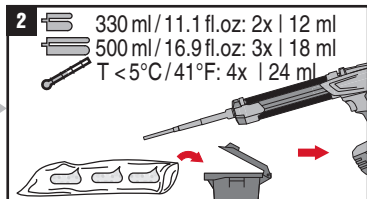
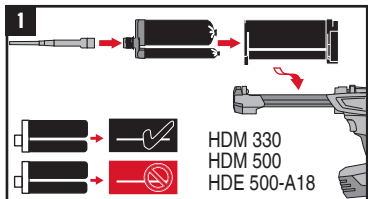
HIT-RE-M  
HIT-SZ

**C**

$h_{ef}$ :  
 $2\frac{3}{8}'' \dots 25''$   
 60...640 mm

HAS/HIT-V   
 HIS-N   
 Rebar 

HIT-RE-M  
 HIT-SZ  
 HIT-OHW  
 HIT-OHC

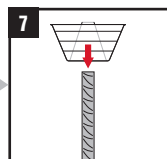
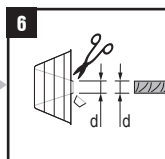
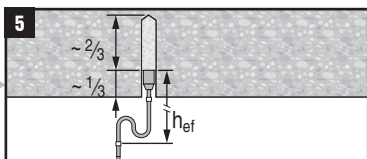
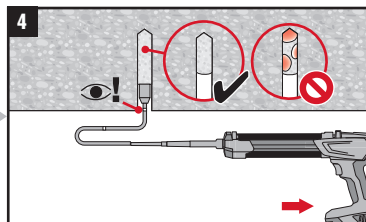
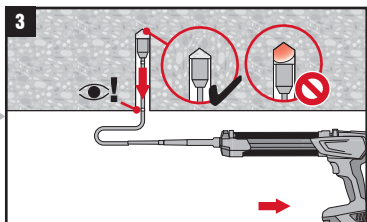
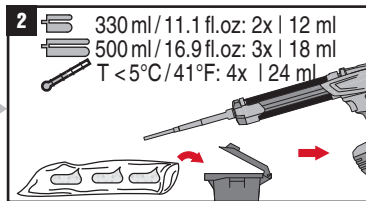
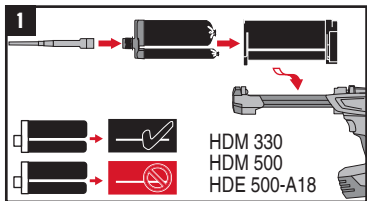

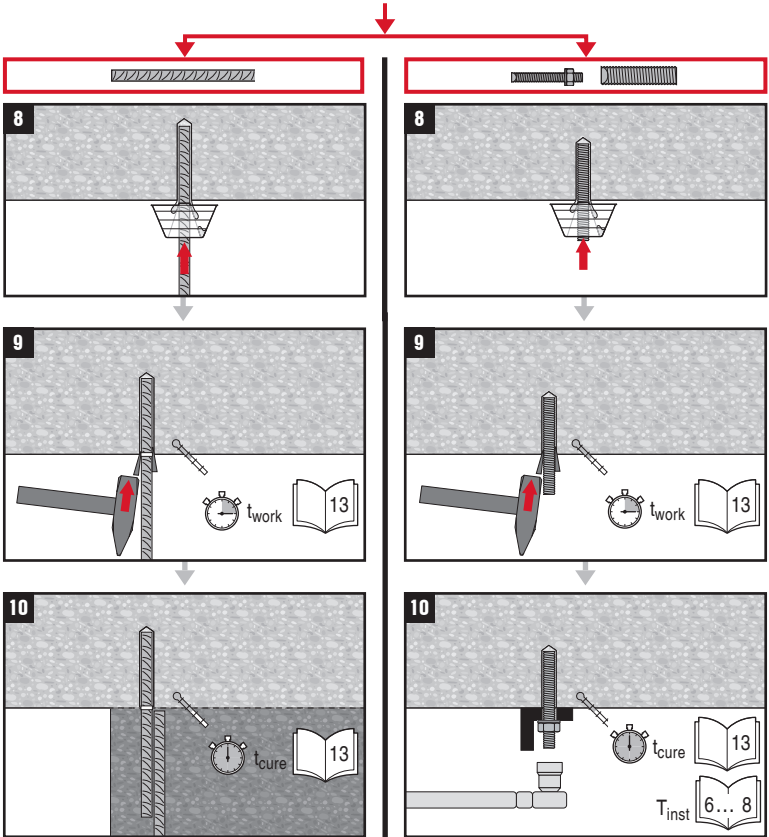

## Adhesive anchoring system for rebar and anchor fastenings in concrete.

### Safety instructions:

**Contains:** Hydroxypropyl methacrylate(A), boric acid (A), dibenzoyl peroxide(B)



(A, B)



(A)



(B)



### Danger

- H317 May cause an allergic skin reaction. (A,B)  
H319 Causes serious eye irritation (A)  
H360 May damage fertility or the unborn child. (A)  
H400 Very toxic to aquatic life. (B)

P262 Do not get in eyes, on skin, or on clothing.

P280 Wear protective gloves/protective clothing/eye protection/face protection.

P302+P352 IF ON SKIN: Wash with plenty of soap and water.

P305+P351+P338 IF IN EYES: Rinse cautiously with water for several minutes. Remove contact lenses, if present and easy to do. Continue rinsing.

P333+P313 If skin irritation or rash occurs: Get medical advice/attention.

P337+P313 If eye irritation persists: Get medical advice/attention.

### Disposal considerations

#### Empty packs:

- ▶ EAK waste material code: 150102 plastic packaging

#### Full or partially emptied packs:

- ▶ Must be disposed of as special waste in accordance with official regulations.
  - EAK waste material code: 08 04 09\* waste adhesives and sealants containing organic solvents or other dangerous substances.
  - or EAK waste material code: 20 01 27\* paint, inks, adhesives and resins containing dangerous substances.

**Content:** 330 ml / 11.1 fl.oz. 500 ml / 16.9 fl. oz **Weight:** 575g / 20,3oz 880g / 31,0oz

**Warranty:** Refer to standard Hilti terms and conditions of sale for warranty information.

Failure to observe these installation instructions, use of non-Hilti anchors, poor or questionable base material conditions, or unique applications may affect the reliability or performance of the fastenings.



**Product Information**

- Always keep these instructions together with the product even when given to other persons.
- Review the MSDS before use.
- **Check expiration date:** See imprint on foil pack manifold (month/year). Do not use expired product.
- **Foil pack temperature during usage:** 0 °C to 40 °C / 32 °F to 104 °F.
- **Base material temperature at time of installation:** between -10 °C and 40 °C / 14 °F and 104 °F.
- **Conditions for transport and storage:** Keep in a cool, dry and dark place between 5 °C and 25 °C / 41 °F and 77 °F.
- For any application not covered by this document / beyond values specified, please contact Hilti.
- **Partly used foil packs must remain in the cassette** and has to be used within **4 weeks**. Leave the mixer attached on the foil pack manifold and store within the cassette under the recommended storage conditions. If reused, attach a new mixer and discard the initial quantity of anchor adhesive.

**NOTICE****▲ Improper handling may cause mortar splashes.**

- Always wear eye protection, gloves and protective clothes during installation.
- Never start dispensing without a mixer properly screwed on.
- Attach a new mixer prior to dispensing a new foil pack (ensure snug fit).
- Use only the type of mixer (HIT-RE-M) supplied with the adhesive. Do not modify the mixer in any way.
- Never use damaged foil packs and/or damaged or unclean foil pack holders (cassettes).

**▲ Poor load values / potential failure of fastening points due to inadequate borehole cleaning.**

- Hilti hollow drill bits TE-CD, TE-YD must be used in conjunction with a properly maintained Hilti vacuum cleaner with model and suction capacity (volumetric flow rate) as specified in the accessory table.
- Holes should be drilled with a rotary hammer drill, using drill bits that comply with ANSI B212.15-1984.
- The boreholes must be free of debris, dust, water, ice, oil, grease and other contaminants prior to adhesive injection.
- For blowing out the borehole – blow out with oil free air until return air stream is free of noticeable dust.
- For brushing the borehole – only use specified wire brush. The brush must resist insertion into the borehole – if not the brush is too small and must be replaced.
- Before inserting anchor/rebar into borehole, mark and set anchor/rebar to the required embedment depth.
- Anchor rods/rebar shall be free of dirt, grease, oil, and other contaminants.

**▲ Ensure that boreholes are filled from the back of the borehole without forming air voids.**

- The annular gap between the anchor/rebar and the borehole shall be filled completely with no gaps.
- If necessary use the accessories / extensions to reach the back of the borehole.
- For overhead applications use the overhead accessories HIT-SZ and take special care when inserting the fastening element. Excess adhesive may be forced out of the borehole. Make sure that no mortar drips onto the installer.

**▲ Not adhering to these setting instructions can result in failure of fastening points!**

## Mortier de scellement pour ancrage de chevilles et d'armatures dans le béton.

### Mesures de sécurité :

**Contient:** hydroxypropyl methacrylate(A), acide borique(A), peroxyde de dibenzoyle(B)



(A, B)



(A)



(B)



#### Danger

- H317 Peut provoquer une allergie cutanée. (A,B)  
H319 Provoque une sévère irritation des yeux.(A)  
H360 Peut nuire à la fertilité ou au fœtus.(A)  
H400 Très toxique pour les organismes aquatiques.(B)

- P262 Éviter tout contact avec les yeux, la peau ou les vêtements.  
P280 Porter des gants de protection/des vêtements de protection/un équipement de protection des yeux/du visage.

- P302+P352 EN CAS DE CONTACT AVEC LA PEAU: laver abondamment à l'eau et au savon.  
P305+P351+P338 EN CAS DE CONTACT AVEC LES YEUX: rincer avec précaution à l'eau pendant plusieurs minutes. Enlever les lentilles de contact si la victime en porte et si elles peuvent être facilement enlevées. Continuer à rincer.

- P333+P313 En cas d'irritation ou d'éruption cutanée: consulter un médecin.  
P337+P313 Si l'irritation oculaire persiste: consulter un médecin. Le produit

### Indications de recyclage

#### Emballages vides :

- code déchets EAK : 150102 Emballages en plastique

#### Emballages pleins ou à moitié vides :

- Les apporter à un centre de collecte des matières dangereuses conformément aux dispositions administratives.
  - Code déchets EAK : 08 04 09\* Résidus de colles et composants pour joints, contenant des solvants organiques ou d'autres substances dangereuses.
  - ou code déchets EAK : 20 01 27\* Peintures, encres d'impression, colles et résines artificielles, contenant des substances dangereuses.

**Contenu :** 330 ml / 11.1 fl.oz. 500 ml / 16.9 fl. oz **Poids :** 575g / 20,3oz 880g / 31,0oz

**Garantie :** Pour les informations sur la garantie, se référer aux conditions générales de vente Hilti.

Le non-respect de ces instructions d'installation, l'utilisation de chevilles non distribuées par Hilti, un matériau support de mauvaise qualité ou de qualité douteuse, ou encore des utilisations particulières peuvent avoir des conséquences néfastes sur la fiabilité ou les performances des ancrages.

## Information produit

- Le présent mode d'emploi doit toujours être conservé avec le produit, même s'il est confié à une autre personne.
- Avant toute utilisation, prendre connaissance de la **fiche de données de sécurité**.
- **Contrôler la date de péremption** (mois/année) imprimée sur le raccord de la cartouche. Ne plus utiliser le produit lorsque la date de péremption est dépassée.
- **Température des cartouches souples en cours d'utilisation:** entre 0 °C et 40 °C / 32 °F et 104 °F.
- **Température du matériau support en cours d'utilisation:** entre –10 °C et 40 °C / 14 °F et 104 °F.
- **Conditions de transport et de stockage:** dans un endroit frais, sec et à l'abri de la lumière à une température de +5 °C à 25 °C / 41 °F à 77 °F.
- En cas d'applications qui ne sont pas décrites dans le présent mode d'emploi ou hors plage de valeurs spécifiées, s'adresser à Hilti.
- **Les cartouches souples entamées doivent rester dans le porte-cartouches** et être réutilisées dans les **quatre semaines**. Laisser la buse mélangeuse vissée et stocker la cartouche souple dans le porte-cartouches conformément à la réglementation. Avant réutilisation, visser une nouvelle buse mélangeuse et jeter le mortier extrudé lors des premières pressions.

### AVIS

#### **▲ En cas de manquement non conforme, il y a risque de projection du mortier.**

- Lors du travail, porter une protection des yeux, des gants et des vêtements de protection!
- Ne jamais commencer l'extrusion si la buse mélangeuse n'est pas vissée!
- Avant de commencer l'extrusion d'une nouvelle cartouche souple, visser une nouvelle buse mélangeuse. Vérifier qu'elle est bien en place.
- Utiliser exclusivement le type de buse fourni avec le mortier (HIT-RE-M). Ne modifier la buse mélangeuse en aucun cas.
- Ne jamais utiliser de cartouches souples endommagées ni de porte-cartouches endommagés ou très encrassés.

#### **▲ Mauvaise fixation/défaillance du chevillage à cause d'un nettoyage insuffisant du trou.**

- Les mèches creuses Hilti TE-CD, TE-YD doivent être associées à un modèle d'aspirateur Hilti bien entretenu d'une capacité d'aspiration (débit volumétrique) conforme à la spécification du tableau des accessoires.
- Les trous doivent être percés à l'aide d'un perceur et de forets conformément à la norme ANSI B212.15-1984.
- Avant de procéder à l'injection, s'assurer que le trou de perçage est exempt de déblais de perçage, poussières, eau, glace, huile, graisse ou autres contaminants.
- Soufflage du trou foré – avec de l'air exempt d'huile jusqu'à ce que l'air sortant soit exempt de toute poussière.
- Brossage du trou foré – uniquement avec un écouvillon en acier adapté. Une résistance doit se faire sentir lors de l'insertion de l'écouvillon dans le trou – si ce n'est pas le cas, l'écouvillon est trop petit et doit être remplacé.
- Identifier et marquer la bonne profondeur d'implantation sur la cheville avant d'insérer celle-ci dans le trou.
- Les tiges d'ancrage/fers à béton doivent être exempts de saleté, de graisse, d'huile et d'autres contaminants.

#### **▲ Veiller à ce que le remplissage se fasse à partir du fond du trou pour éviter la formation de bulles d'air.**

- L'espace entre la cheville/fer à béton et le trou de perçage doit être complètement rempli sans aucun espace laissé vide.
- Si nécessaire, utiliser des prolongateurs pour atteindre le fond du trou.
- En cas d'applications au plafond, utiliser l'accessoire HIT-SZ et faire particulièrement attention lors de l'introduction de l'élément de fixation. L'excédent de mortier peut ressortir du trou foré. Veiller alors à ce que celui-ci ne goutte pas sur l'opérateur.

#### **▲ Le non-respect des instructions peut entraîner une défaillance du chevillage!**

## Resina de inyección para la fijación de anclajes y tacos en hormigón.

**Contiene:** metacrilato de hidroxipropilo(A), ácido bórico (A) peróxido de dibenzoilo(B)



(A, B)



(A)



(B)



### Peligro

- |      |   |
|------|---|
| H319 | Provoca irritación ocular grave. (A,B)              |
| H317 | Puede provocar una reacción alérgica en la piel.(A) |
| H360 | Puede perjudicar la fertilidad o dañar al feto. (A) |
| H400 | Muy tóxico para los organismos acuáticos. (B)       |

- |      |   |
|------|---|
| P262 | Evitar el contacto con los ojos, la piel o la ropa. |
| P280 | Llevar guantes/prendas/gafas/máscara de protección. |

P305+P351+P338 EN CASO DE CONTACTO CON LOS OJOS: Aclarar cuidadosamente con agua durante varios minutos. Quitar las lentes de contacto, si lleva y resulta fácil. Seguir aclarando.

P333+P313 En caso de irritación o erupción cutánea: Consultar a un médico.

P337+P313 Si persiste la irritación ocular: Consultar a un médico.

P302+P352 EN CASO DE CONTACTO CON LA PIEL: Lavar con agua y jabón abundantes.

### Indicaciones de reciclaje

#### Cartuchos vacíos:

- el código de residuo LER: 150102 embalajes de plástico

#### Cartuchos llenos o parcialmente vacíos:

- Deberán eliminarse como residuos especiales de acuerdo con las normativas oficiales.
  - Código de residuo LER: 08 04 09\* Residuos de adhesivos y sellantes que contienen disolventes orgánicos u otras sustancias peligrosas.
  - O el código de residuo LER: 20 01 27\* Pinturas, tintas, adhesivos y resinas que contienen sustancias peligrosas.

**Contenido:** 330 ml / 11.1 fl.oz. 500 ml / 16.9 fl. oz **Peso:** 575g / 20,3oz 880g / 31,0oz

**Garantía:** consulte los términos y condiciones estándar de venta Hilti para obtener más datos sobre la garantía.

El incumplimiento de las instrucciones de uso y datos de fijación, el uso de anclajes no fabricados por Hilti, el estado deficiente o cuestionable del hormigón o ciertas aplicaciones puede afectar a la fiabilidad y rendimiento de la fijación.

## Información del producto

- Conserve las presentes instrucciones de uso siempre junto con el producto y entréguelas también si el producto pasa a manos de otra persona.
- Consulte la **hoja de datos de seguridad** antes de utilizar el producto.
- **La fecha de caducidad** se indica en la pieza de conexión (mes/año). El producto no debe utilizarse después de la fecha de caducidad.
- **Temperatura del cartucho durante la utilización:** de 0 °C a 40 °C / de 32 °F a 104 °F.
- **Temperatura del material base durante la instalación:** de -10 °C a 40 °C / de 14 °F a 104 °F.
- **Condiciones de transporte y almacenamiento:** lugar fresco, seco y oscuro con una temperatura de +5 °C a 25 °C / de 41 °F a 77 °F.
- Para aplicaciones que no se describen en las presentes instrucciones de uso o no se enmarcan en la especificación, póngase en contacto con Hilti.
- **Los cartuchos que no estén completamente vacíos deberán permanecer en el portacartuchos** y utilizarse antes de **cuatro semanas**. Para ello deberán guardarse en el portacartuchos con el mezclador enroscado en las condiciones de almacenamiento recomendadas. Antes de utilizarlo de nuevo, enroscar un nuevo mezclador y desechar la resina inicial.

### AVISO

#### **▲ La resina puede salpicar si se utiliza incorrectamente.**

- Lleve gafas protectoras, guantes de protección y ropa de trabajo durante el trabajo.
- No comience a inyectar si no se ha roscado el mezclador.
- Enrosque un nuevo mezclador antes de trabajar con un cartucho nuevo. Asegúrese de que el mezclador está unido firmemente.
- Utilice exclusivamente el modelo de mezclador (HIT-RE-M) suministrado con la resina. No modifique el mezclador en ningún caso.
- No utilice cartuchos en mal estado y/o portacartuchos dañados o sucios.

#### **▲ Valores de sujeción deficientes/fallo de la fijación debido a limpieza insuficiente del agujero.**

- Las brocas huecas TE-CD, TE-YD de Hilti deben utilizarse con una aspiradora de Hilti en buen estado de funcionamiento del modelo y la capacidad de succión (tasa de flujo volumétrico) que se especifican en la tabla de accesorios.
- El taladro deberá ser ejecutado con un martillo electro neumático, utilizando brocas que cumplan la norma ANSI B212.15-1984.
- Antes de inyectar la resina, los agujeros deben estar libres de restos de perforación, polvo, agua, hielo, aceite, grasa o cualquier otro agente contaminante.
- Soplado del agujero con aire sin aceite hasta que el aire que refluye esté libre de polvo.
- Limpieza del agujero: realícese sólo con un cepillo metálico de tamaño apropiado. Al cepillar el agujero, se notará cierta resistencia en el cepillo. Si no es este el caso, el cepillo es demasiado pequeño y debe cambiarse.
- Antes de introducir la varilla/corrugado en el taladro, marque la varilla/corrugado con la profundidad de empotramiento necesaria.
- La varilla/corrugado debe estar libre de suciedad, oleos y otros contaminantes.

#### **▲ Verificar que el relleno del agujero se produce desde el fondo del mismo para que no se formen burbujas de aire.**

- El espacio anular entre la varilla/corrugado y el taladro deberá rellenarse completamente sin hueco alguno.
- Si es necesario, utilice las prolongaciones para alcanzar el fondo del agujero.
- En aplicaciones por encima de la cabeza, utilice el accesorio HIT-SZ y preste especial atención al introducir el elemento de fijación. Puede salir resina sobrante del agujero. Asegúrese de que la resina no gotee sobre el usuario.

#### **▲ El incumplimiento de estas instrucciones puede llevar a una fijación incorrecta.**

**Buchas químicas para fixações de ferros e de ancoragens em betão.****Instruções de segurança:**

**Contém:** metacrilato de hidroxipropilo(A), ácido bórico (A), peróxido de dibenzoilo(B)



(A, B)



(A)



(B)

**Perigo**

H317 Pode provocar uma reacção alérgica cutânea. (A,B)

H319 Provoca irritação ocular grave.(A)

H360 Pode afectar a fertilidade ou o nascituro.(A)

H400 Muito tóxico para os organismos aquáticos. (A)

P262 Não pode entrar em contacto com os olhos, a pele ou a roupa.

P302+P352 SE ENTRAR EM CONTACTO COM A PELE: lavar com sabonete e água abundantes.

P280 Usar luvas de protecção/vestuário de protecção/protecção ocular/protecção facial.

P305+P351+P338 SE ENTRAR EM CONTACTO COM OS OLHOS: enxaguar cuidadosamente com água durante vários minutos. Se usar lentes de contacto, retire-as, se tal lhe for possível. Continuar a enxaguar.

P333+P313 Em caso de irritação ou erupção cutânea: consulte um médico.

P337+P313 Caso a irritação ocular persista: consulte um médico.

**Recomendação sobre a eliminação****Cartuchos vazios:**

► código CER: 150102 Embalagens de plástico

**Cartuchos semiusados ou novos:**

► Eliminar de acordo com as normas e regulamentações legais sobre resíduos especiais.

– Código CER: 08 04 09\* Resíduos de colas ou vedantes, contendo solventes orgânicos ou outras substâncias perigosas.

– ou código CER: 20 01 27\* Tintas, produtos adesivos, colas e resinas, contendo substâncias perigosas.

**Conteúdo:** 330 ml / 11.1 fl.oz. 500 ml / 16.9 fl. oz **Peso:** 575g / 20,3oz 880g / 31,0oz

**Garantia:** Consulte os termos e condições de venda Hilti padrão para informações sobre garantia.

O não cumprimento destas instruções de instalação, a utilização de ancoragens não Hilti, condições deficientes ou duvidosas do material base ou aplicações únicas podem afectar a fiabilidade ou desempenho das fixações.

**Dados informativos sobre o produto**

- Guarde estas instruções de utilização sempre junto com o produto, mesmo quando o entregar a outras pessoas.
- Antes de iniciar os trabalhos, tenha em consideração a **ficha técnica de segurança**.
- **Veja o prazo de validade** (mês/ano) na peça de junção. Não utilize produtos cujo prazo de validade se encontre ultrapassado.
- **Temperatura do cartucho durante a utilização:** entre 0 °C e 40 °C / 32 °F e 104 °F.
- **Temperatura do material base durante a instalação:** entre -10 °C e 40 °C / 14 °F e 104 °F.
- **Condições de transporte e armazenamento:** em lugar fresco, seco e ao abrigo da luz, entre +5 °C e 25 °C / 41 °F e 77 °F.
- Em caso de aplicações que não se encontrem descritas nas presentes instruções de utilização ou estejam fora das especificações, é favor dirigir-se à Hilti.
- **As sobras de cartuchos parcialmente usados devem permanecer no suporte** e ser utilizadas num prazo de **quatro semanas**. Deixe o misturador enroscado e armazene-o no suporte juntamente com o cartucho, de acordo com as condições de armazenagem preconizadas. Quando/se reutilizados, utilize um misturador novo e não utilize novamente a resina inicial.

**⚠ AVISO****⚠ No caso de manuseamento incorrecto, é possível que seja injectada resina.**

- Durante a realização de trabalhos, use óculos de protecção, luvas de protecção e roupa de trabalho!
- Nunca comece a aplicação sem que o misturador esteja enroscado!
- Antes da aplicação de um novo cartucho, enrosque um misturador novo. Certifique-se de que está bem apertado.
- Utilizar apenas o tipo de misturador (HIT-RE-M) fornecido com a resina. Não modifique o misturador de forma alguma.
- Nunca utilize cartuchos danificados e/ou suportes danificados ou sujos.

**⚠ Valores de retenção deficientes/falha da fixação devido a limpeza insuficiente do furo.**

- A brocas de perfuração ocas Hilti TE-CD e TE-YD têm de ser usadas em conjunto com um aspirador Hilti em boas condições de funcionamento e com o modelo e capacidade de aspiração (débito volumétrico) especificados na tabela dos acessórios.
- O furo deverá ser executado com um perfurador electro pneumático, utilizando brocas que cumpram a norma ANSI B212.15-1984.
- Antes da injeção, os furos têm de estar isentos de material de perfuração, pó, água, gelo, óleo, gordura ou outras impurezas.
- Limpar o furo por sopra com ar isento de óleo, até que o ar saia sem pó.
- Escovar o furo – apenas com uma escova de aço adequada. Ao escovar o furo deverá ser perceptível uma resistência na escova – se não for o caso, a escova é demasiado pequena e deverá ser substituída.
- Antes de inserir a Barra roscada/Ferros de armadura no furo, marque a Barra roscada/Ferros de armadura com a profundidade de embhecimento necessária.
- A barra roscada/ferro de armadura deve estar livre de sujidade, óleos e outros contaminantes.

**⚠ Assegure que o enchimento do furo é efectuado a partir do fundo, para que não se formem bolhas de ar.**

- O espaço anular entre a Barra roscada/Ferros de espera e o furo deve ser preenchido completamente sem falhas.
- Se necessário, utilize os prolongadores para alcançar o fundo do furo.
- No caso de aplicações em suspensão, utilize o acessório HIT-SZ e preste especial atenção ao inserir o elemento de fixação. Pode sair resina em excesso do furo. Certifique-se de que não pinga resina sobre o utilizador.

**⚠ A não observação das instruções pode conduzir à falha da fixação!**

**Связующий состав для крепления арматурных стержней и анкеров в бетоне**

**Safety instructions:**

**Содержит:** гидроксипропилметакрилат(A), Борная кислота (A), Перекись бензоила(B)



(A, B)



(A)



(B)



**Опасно**

- |                |  |
|----------------|--|
| H317           | Может вызвать аллергическую реакцию на коже. (A,B)   |
| H319           | Вызывает серьёзное раздражение глаз.(A)  |
| H360           | Может отрицательно повлиять на способность к деторождению или на неродившегося ребёнка.(A)   |
| H400           | Очень токсично для водных организмов. (B)  |
| P262           | Избегать попадания в глаза, на кожу или на одежду.   |
| P280           | Надеть защитные перчатки (рукавицы) / защитную одежду / защитные очки / защитную маску.  |
| P302+P352      | ПРИ ПОПАДАНИИ НА КОЖУ: Промыть большим количеством воды с мылом.   |
| P305+P351+P338 | ПРИ ПОПАДАНИИ В ГЛАЗА: Осторожно промыть глаза водой в течение нескольких минут. Снять контактные линзы, если вы ими пользуетесь и если это легко сделать. Продолжить промывание глаз. |
| P333+P313      | При раздражении кожи или кожных высыпаниях: Обратиться за медицинской консультацией / помощью.   |
| P337+P313      | При длительном раздражении глаз: Обратиться за медицинской консультацией / помощью.  |

**Указания по утилизации**

**Пустые капсулы:**

- ▶ код отходов по ЕАК: 150102 Упаковки из полимерных материалов

**Полные/частично заполненные капсулы:**

- ▶ утилизировать в соответствии с действующими нормами как отходы, подлежащие специальной обработке.
  - Код отходов по ЕАК: 20 01 27\* Краски, типографские краски, клеящие вещества и синтетические смолы, содержащие опасные вещества.
  - или ЕАК-№г. 08 04 09\* Остатки адгезивов и герметиков, содержащие органические растворители или другие опасные вещества.

**Ёмкость:** 330 мл/11.1 жидк. унц.      500 мл/16.9 жидк. унц.      **Масса:** 575 г/20.3 унц.      880 г/31.0 унц.

Hilti не несёт ответственность за повреждения, вызванные следующими обстоятельствами:

- нарушение предписанных условий хранения и транспортировки;
- несоблюдение указаний инструкции по применению и установочных данных;
- неправильный расчёт анкерного крепления;
- недостаточная несущая способность основания;
- неправильное использование;
- другие факторы, которые неизвестны Hilti или не входят в сферу ответственности Hilti (например использование продуктов другого производителя).



**Информация о продукте**

- Храните данную инструкцию по применению всегда вместе с продуктом. Передавайте продукт другим лицам только вместе с инструкцией по применению.
- Сертификат безопасности: Перед началом работ ознакомьтесь с информацией из сертификата безопасности.
- Срок годности: Проверьте срок годности (месяц/год) на капсуле. Не используйте продукт после истечения срока годности.
- Температура капсулы во время использования: 0–40 °C/32–104 °F.
- Температура основания во время установки: от –10 °C до 40 °C/от 14 °F до 104 °F.
- Условия транспортировки и хранения: хранить в прохладном, сухом и тёмном месте при температуре 5–25 °C/41–77 °F.
- При использовании, описание которого в настоящей инструкции по применению не приводится или выходит за рамки, указанные в спецификации, обращайтесь в Hilti.
- Не использованные до конца плёночные капсулы можно использовать в течение четырёх недель. Для этого оставьте навинченный смеситель на капсуле и храните капсулу в соответствии с инструкциями. При повторном использовании упаковки наверните новый смеситель и удалите первичный состав.

**▲ УВЕДОМЛЕНИЕ****▲ При неправильном обращении возможно разбрызгивание раствора**

- Во время работы носите плотно прилегающие защитные очки, защитные перчатки и рабочую одежду!
- Не начинайте выдавливание без навинченного смесителя!
- Перед выдавливанием новой плёночной капсулы приверните новый смеситель. Убедитесь в том, что смеситель привёрнут плотно.
- Используйте только входящий в комплект поставки состава смеситель. Ни в коем случае не меняйте смеситель.
- Ни в коем случае не используйте повреждённые капсулы и/или повреждённые/сильно загрязнённые кассеты.

**▲ Плохое крепление/отсутствие фиксации крепления вследствие неудовлетворительной очистки отверстия.**

- Пустотелые буры Hilti TE-CD и TE-YD необходимо использовать в сочетании с правильно подключенным пылесосом Hilti, модель и мощность всасывания которого (объемная скорость потока) соответствуют указанным в таблице информации о дополнительных принадлежностях.
- Перед инъецированием следует очистить отверстия от буровой крошки, пыли, воды, льда, масла, смазки или других загрязнений.
- Продувка отверстия: продувайте отверстие воздухом, очищенным от масла, до выхода из отверстия воздуха без пыли.
- Промывка отверстия: с помощью водяного шланга при нормальном давлении промывайте отверстие до выхода чистой воды.

**▲ Во избежание появления воздушных пузырей убедитесь в том, что заполнение отверстия происходит от его основания.**

- При необходимости используйте удлинители, чтобы доставать до основания отверстия.
- При выполнении работ над головой используйте дополнительное приспособление HIT-SZ и будьте особенно внимательны при установке (вводе) крепёжного элемента. Из отверстия могут выходить излишки раствора. Убедитесь в том, что раствор не попадает на пользователя.

**▲ Несоблюдение указаний может привести к отсутствию фиксации крепления!**





















- ar** Hilti Argentina S.R.L.  
Profesor Manuel García 4760  
B1605 BIB - Munro  
AR-Buenos Aires  
Tel +54 11 4721 4400
- au** Hilti (Aust.) Pty. Ltd.  
Level 5, 1G Homebush Bay Drive  
Rhodes N.S.W. 2138  
Tel +61 2 8748 1000
- br** Hilti do Brasil Comercial Ltda.  
Av. Ceci, 426-Centro Empresarial  
Tamboré  
06460-120 Barueri, SP  
Tel +55 11 4134 9000
- ca** Hilti (Canada) Corp.  
2360 Meadowpine Boulevard  
Mississauga, Ontario L5N 6S2  
Tel +1 905 813 9200
- cl** Hilti Chile Ltda.  
Av. Apoquindo 4501, piso 13  
Las Condes 7550000  
Santiago  
Tel +562 655 3000
- cr** Superba S.A.  
200 Mts. Oeste de Matra la Uruca  
CR-San José  
Tel +506 2255 1044
- mx** Hilti Mexicana, S.A. de C.V.  
Jaime Balmes 8, Oficina 102, 1er Piso  
Col. Los Morales Polanco  
Del. Miguel Hidalgo  
MEX-Mexico City 11510  
Tel +5255 5387-1600
- ru** Hilti Distribution Ltd.  
Business park ZAO „Greenwood“  
MKAD 69 km, bldg. 3  
Krasnogorsky rajon, p/o Putilkovo  
RU-143441 Moskau region  
CS: • +7 495 792 52 52
- us** Hilti, Inc.  
7250 Dallas Parkway, Suite 1000  
US-Plano, TX 75024  
Tel +1 918 872 3000

<b>CE</b>
14
Hilti Corporation, LI-9494 Schaan Hilti Werke
0756
0756-CPR-0612
ETA-14/0001
ETAG001-1, -5
TR 23
<a href="http://www.hilti.group">www.hilti.group</a>

<b>CE</b>
14
Hilti Corporation, LI-9494 Schaan Hilti Werke
0756
0756-CPR-0613
ETA-14/0009
ETAG001-1, -5
Option 1
<a href="http://www.hilti.group">www.hilti.group</a>



Certified to  
NSF/ANSI/CAN 61

## Made in Germany

Hilti = registered trademark of  
Hilti Corporation, Schaan, Liechtenstein  
[www.hilti.group](http://www.hilti.group)

© 2024 Right of technical changes reserved S.E. & O



2080669 V7-04.2024